

Optimization in Water Pumping Systems using Parallel Pumping

Tony J Furst MSEd, CPD, LEED AP

RSEC Manager US – Application Engineering

Armstrong Fluid Technology

Learning Objectives

The fundamental concepts of parallel pumping

How we can meet a system's flow and head needs using a variety of pumping arrangements

How parallel pumping can be used to not only accommodate, but optimize different design criteria

Perceived Barriers to Parallel Pumping

Parallel pumping allows us to satisfy the needs of a system in a variety of ways

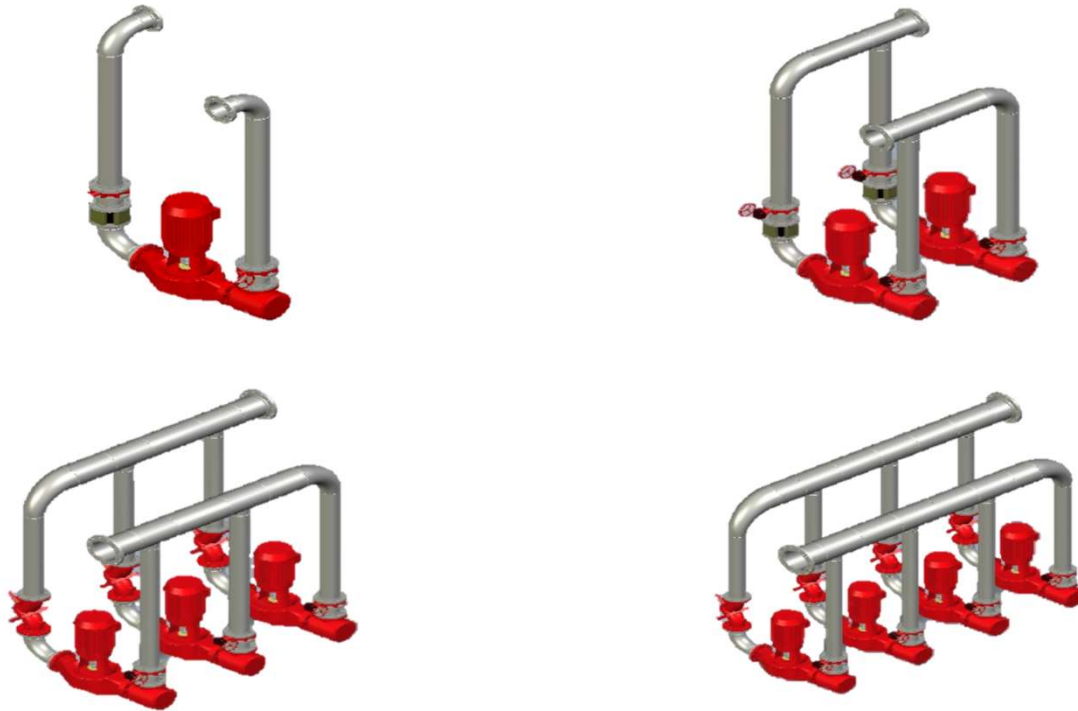

Parallel Pumping Basics

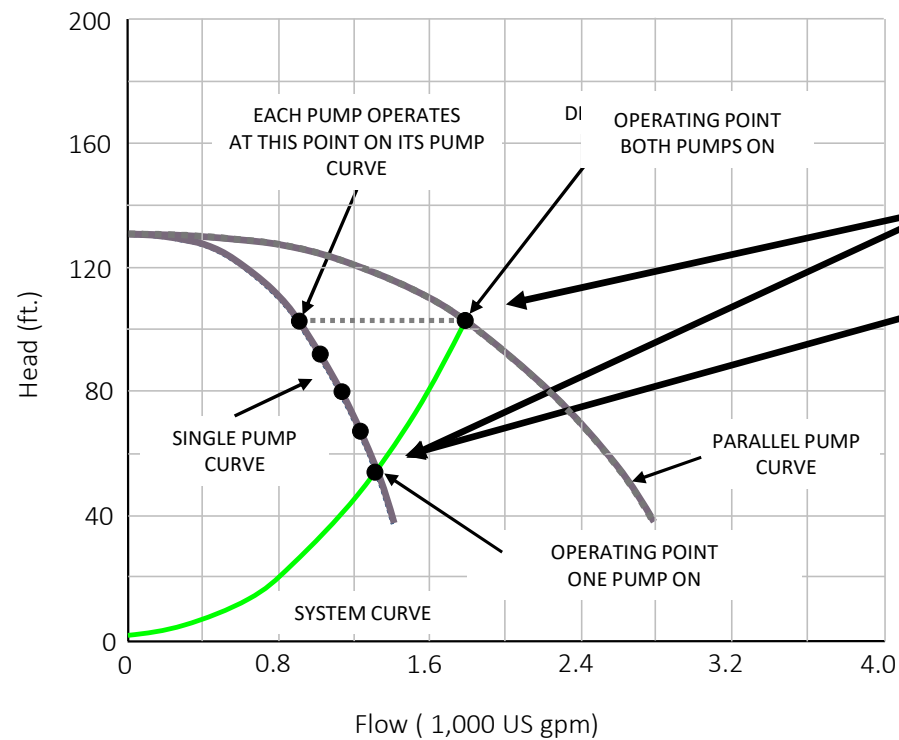

RULES for Parallel Pumping:

- * All pumps *must* be identical
- * The System Curve *must* intersect *both* pump curves
- * Motor must be sized based on single pump operating point



Single Pump Curve vs. Parallel Pump Curve

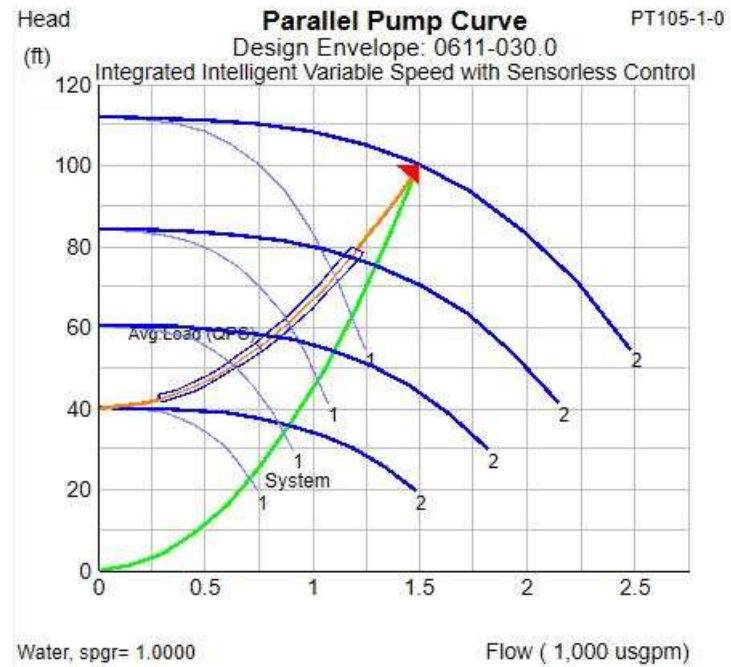
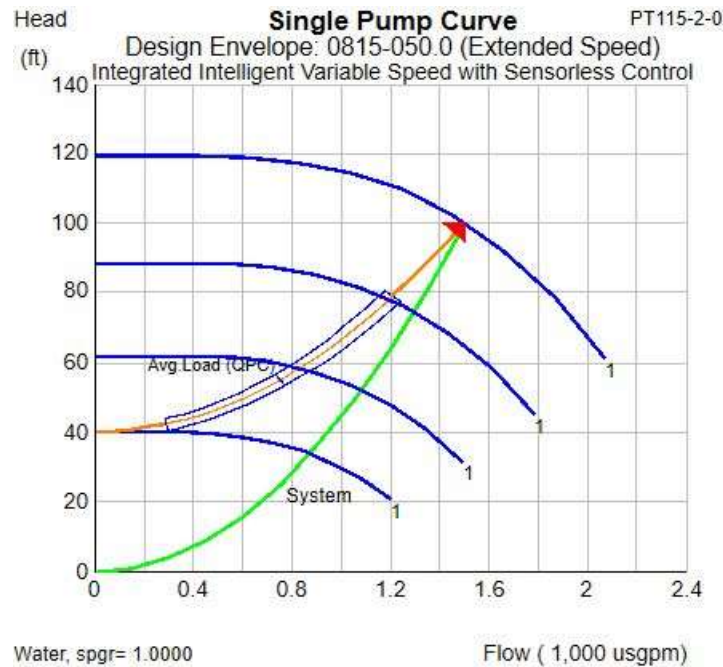

3 Pumps in Parallel vs. 4 Pumps in Parallel

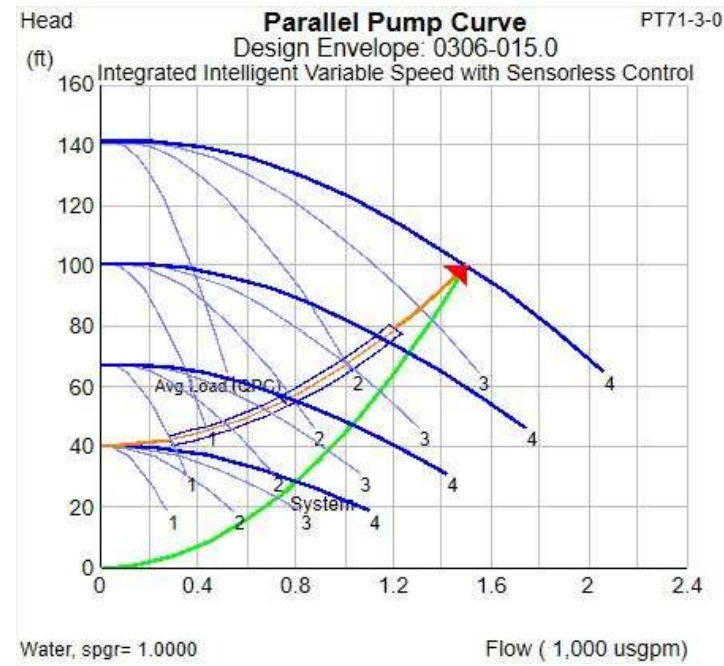
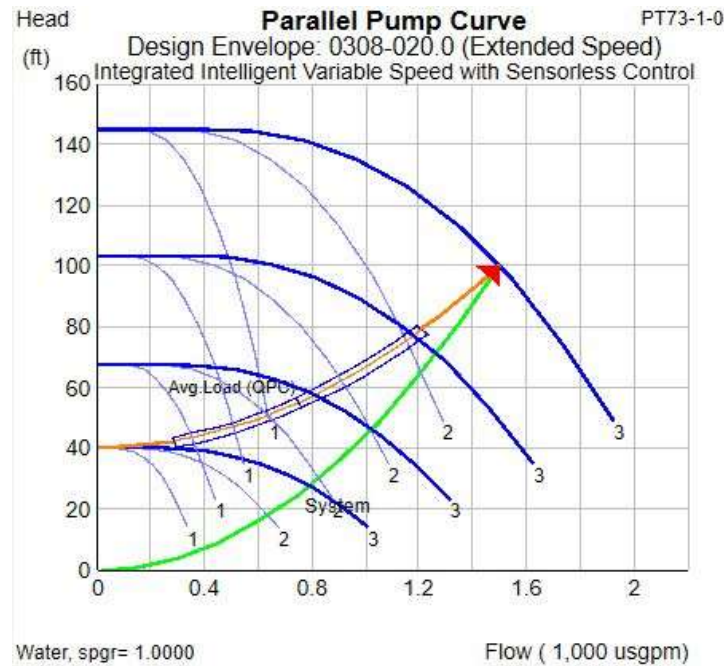

Efficiency curve behavior of pumps in parallel

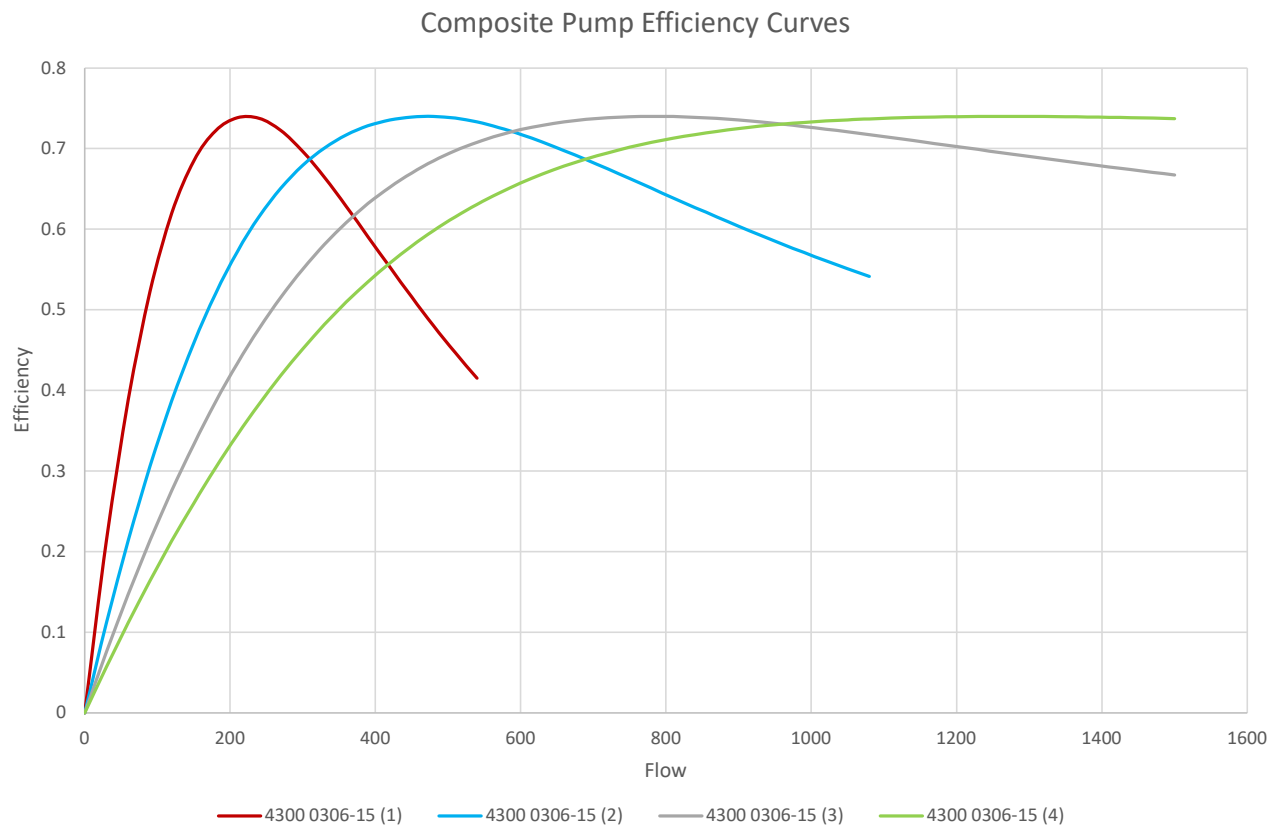

Comparison Outline

All pumping systems shown were designed to meet a duty point of 1500 GPM @ 100 ft.

Duty Pumps	Standby Pumps	Each Pump Sized for...
1	1	100%
2	0	50%
2	0	75%
2	1	50%
3	0	33%
4	0	25%
3	1	33%

Criteria Considered
Pump Cost
Installation Cost
Operating Cost
Maintenance Cost
Footprint
Redundant Flow Capacity
POR Coverage

The Traditional Approach

Two Pumps Sized for 100% Flow @ Design Head (Duty/Standby)

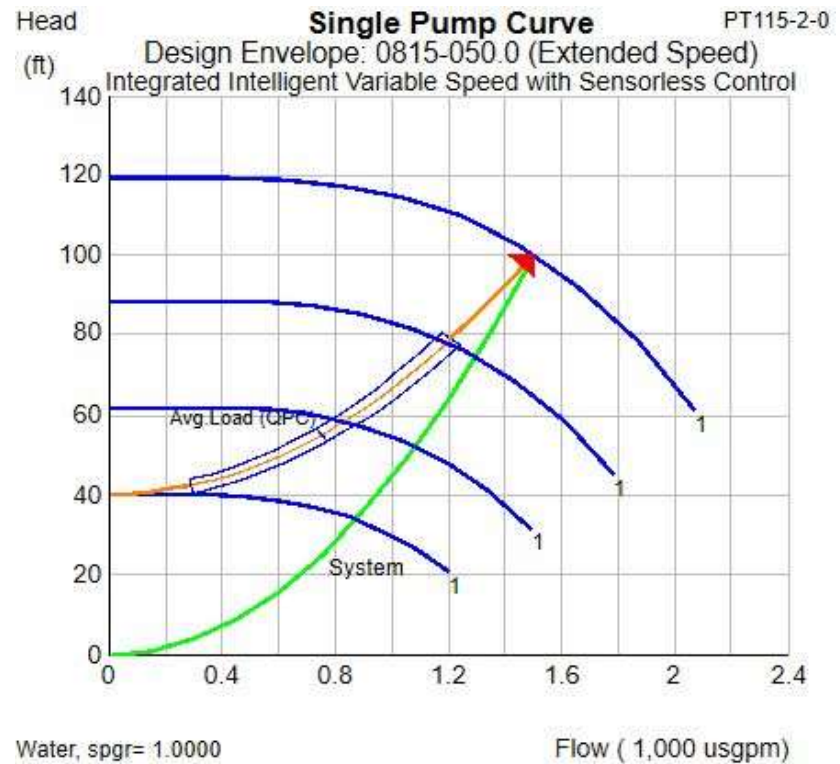
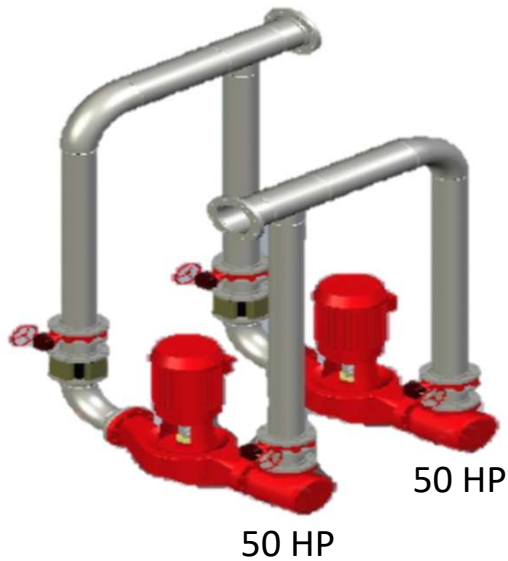

The Two-Pump Parallel Approach

Each pump sized for 50% flow

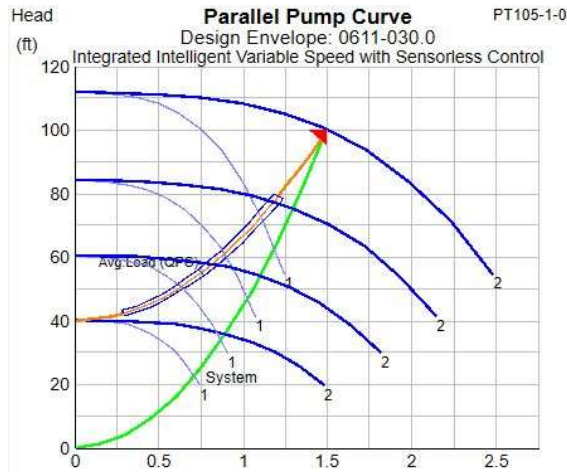

Each pump sized for 75% flow

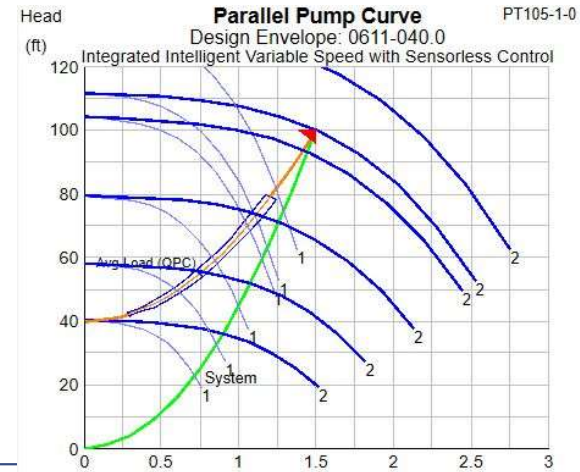

The Three-Pump Parallel Approach

Each pump sized for 33% flow

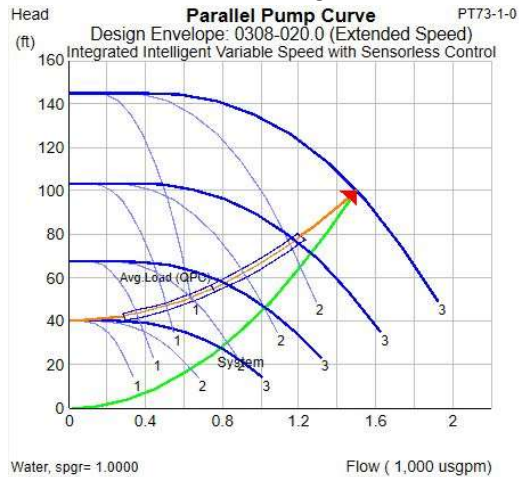
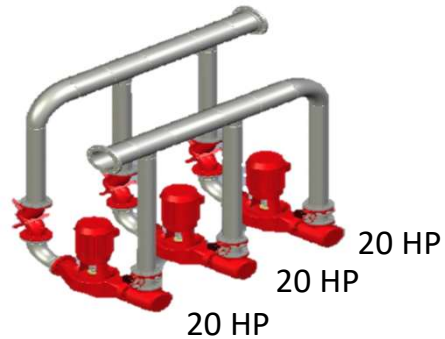

Each pump sized for 50% flow

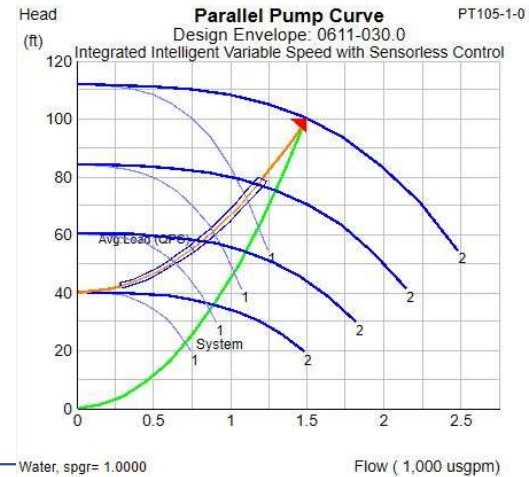

The Four-Pump Parallel Approach

Each pump sized for 25% flow

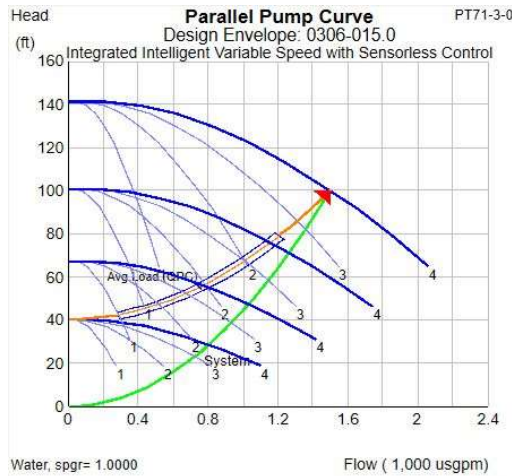
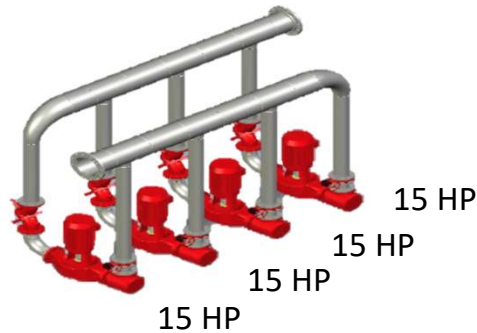

Each pump sized for 33% flow

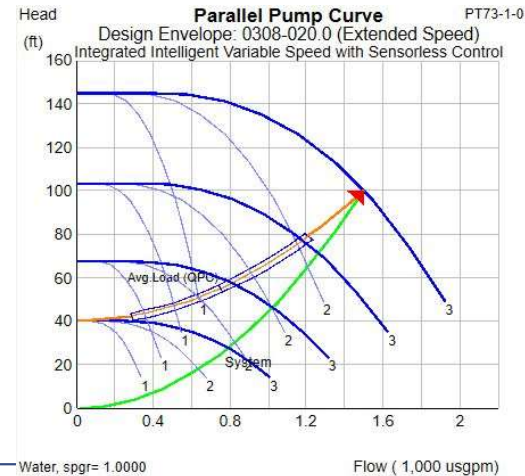
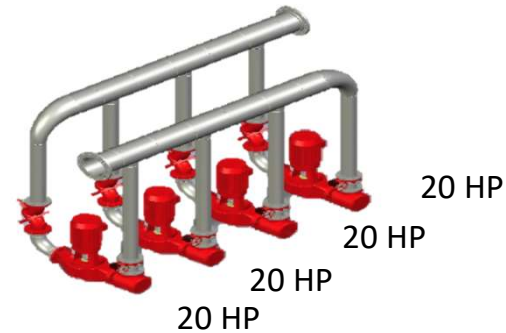

Summary of All Design Strategies

Duty	SB	Flow Per Pump	Pump Selection
1	1	100%	0815 – 50 HP
2	0	50%	0611 – 30 HP
2	0	75%	0611 – 40 HP
2	1	50%	0611 – 30 HP
3	0	33%	0308 – 20 HP
3	1	33%	0308 – 20 HP
4	0	25%	0306 – 15 HP

Perceived Barriers to Parallel Pumping

- Purchase Price
- Installation Cost
- Footprint
- Operating Cost
- Maintenance
- Redundancy
- Control Complexity

Perceived barriers to parallel pumping

“It costs more money up front to purchase and install more pumps”

Vertical Inline Split-Coupled Pump

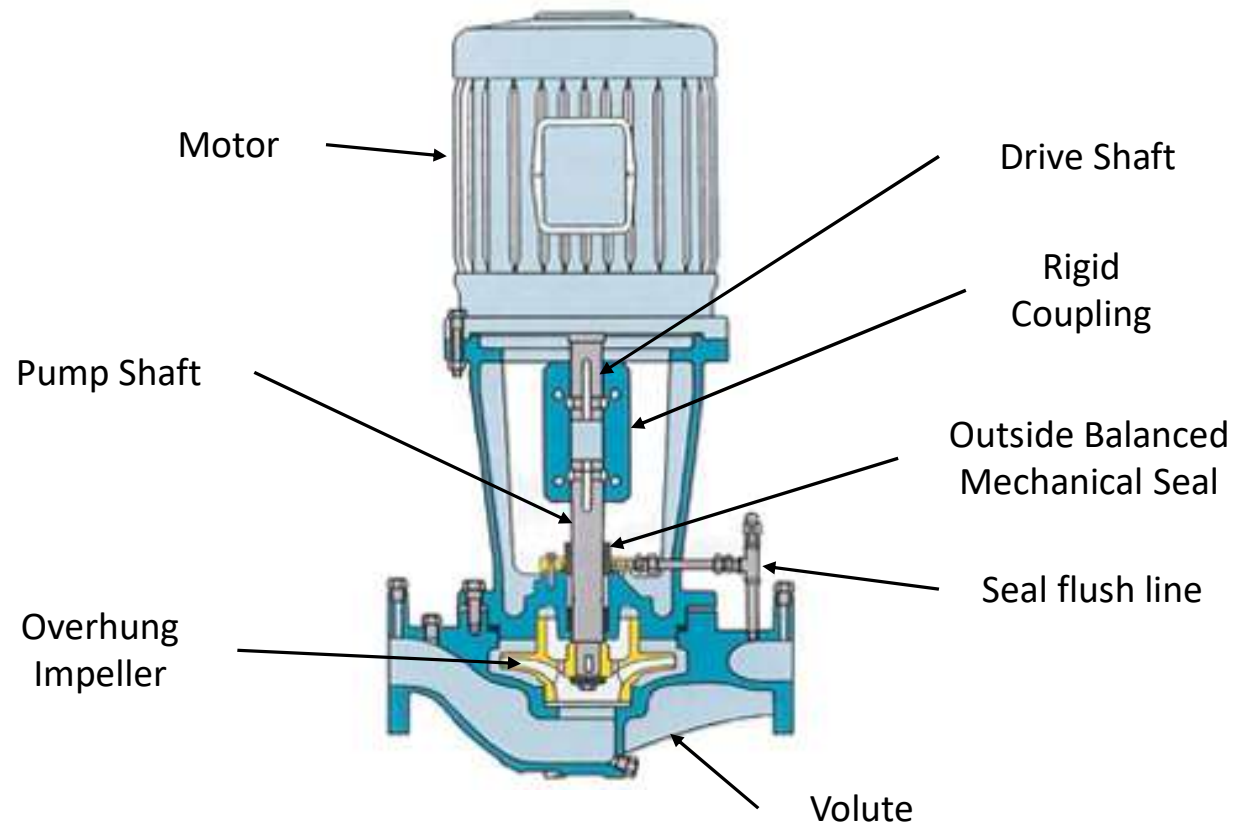

Typical Horizontal End-Suction Installation

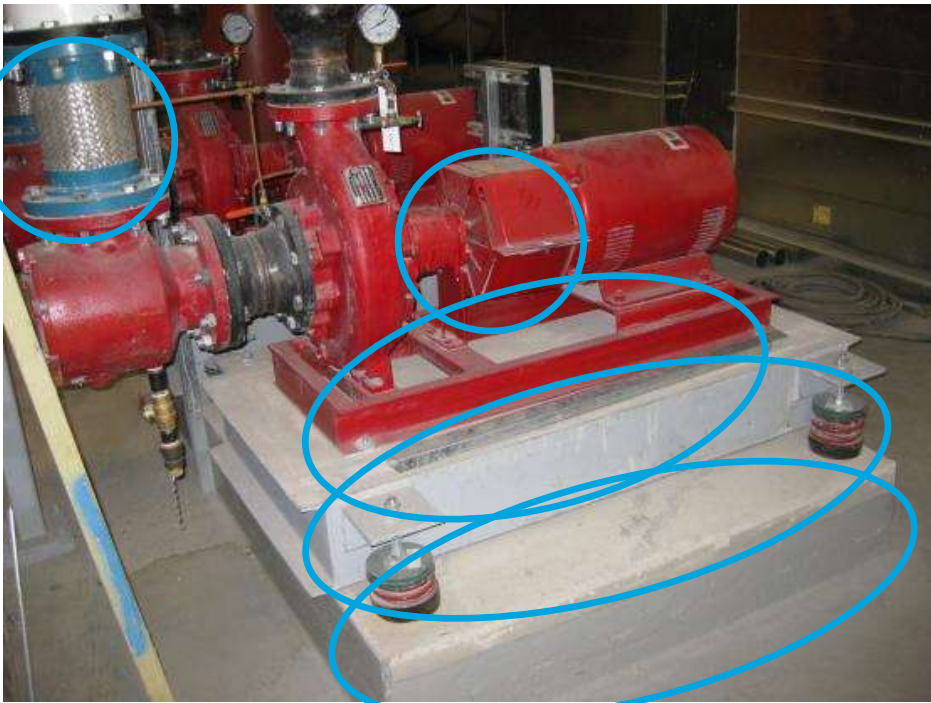

Coupling re-alignment

Grouting

Inertia pad

Concrete base

Flex connectors

A Simplified System with Built-In Components



VS.



- Pre-Mounted VFD w/ Proper Cable and Grounding
- DC Link Chokes Equivalent to 5% AC Line Reactor
- Energy and Flow Metering with +/- 5% Accuracy
- RFI Filtering Designed to Meet IEC 61800-3
- Thermistors and Tripping Relays
- DC Current Trickle to Replace Space Heaters

Installation Cost Comparison

Duty	SB	Flow per Pump	Pump Selection	Piping Cost	Pump Installation	Pump Wiring	Total Installation Cost
1	1	100%	0815 – 50 HP	\$21,350	\$2,880	\$940	\$25,170
2	0	50%	0611 – 30 HP	\$15,580	\$2,560	\$740	\$18,880
2	0	75%	0611 – 40 HP	\$21,350	\$2,720	\$820	\$24,890
2	1	50%	0611 – 30 HP	\$23,380	\$3,840	\$1,100	\$28,320
3	0	33%	0308 – 20 HP	\$20,150	\$3,600	\$880	\$24,630
3	1	33%	0308 – 20 HP	\$26,870	\$4,800	\$1,170	\$32,840
4	0	25%	0306 – 15 HP	\$26,870	\$4,480	\$1,060	\$32,410

Total First Cost Comparison

Duty	SB	Flow Per Pump	Pump Selection
1	1	100%	0815 – 50 HP
2	0	50%	0611 – 30 HP
2	0	75%	0611 – 40 HP
2	1	50%	0611 – 30 HP
3	0	33%	0308 – 20 HP
3	1	33%	0308 – 20 HP
4	0	25%	0306 – 15 HP

Total First Cost Comparison

Duty	SB	Flow Per Pump	Pump Selection	Total Purchase Price
1	1	100%	0815 – 50 HP	\$32,880
2	0	50%	0611 – 30 HP	\$15,660
2	0	75%	0611 – 40 HP	\$17,370
2	1	50%	0611 – 30 HP	\$23,490
3	0	33%	0308 – 20 HP	\$16,160
3	1	33%	0308 – 20 HP	\$21,560
4	0	25%	0306 – 15 HP	\$20,080

Total First Cost Comparison

Duty	SB	Flow Per Pump	Pump Selection	Total Purchase Price	Total Installation Cost
1	1	100%	0815 – 50 HP	\$32,880	\$25,170
2	0	50%	0611 – 30 HP	\$15,660	\$18,880
2	0	75%	0611 – 40 HP	\$17,370	\$24,890
2	1	50%	0611 – 30 HP	\$23,490	\$28,320
3	0	33%	0308 – 20 HP	\$16,160	\$24,630
3	1	33%	0308 – 20 HP	\$21,560	\$32,840
4	0	25%	0306 – 15 HP	\$20,080	\$32,410

Total First Cost Comparison

Duty	SB	Flow Per Pump	Pump Selection	Total Purchase Price	Total Installation Cost	Total First Cost
1	1	100%	0815 – 50 HP	\$32,880	\$25,170	\$58,050
2	0	50%	0611 – 30 HP	\$15,660	\$18,880	\$34,540
2	0	75%	0611 – 40 HP	\$17,370	\$24,890	\$42,260
2	1	50%	0611 – 30 HP	\$23,490	\$28,320	\$51,810
3	0	33%	0308 – 20 HP	\$16,160	\$24,630	\$40,790
3	1	33%	0308 – 20 HP	\$21,560	\$32,840	\$54,400
4	0	25%	0306 – 15 HP	\$20,080	\$32,410	\$52,490

Total First Cost Comparison

Duty	SB	Flow Per Pump	Pump Selection	Total Purchase Price	Total Installation Cost	Total First Cost	Total HP
1	1	100%	0815 – 50 HP	\$32,880	\$25,170	\$58,050	100
2	0	50%	0611 – 30 HP	\$15,660	\$18,880	\$34,540	60
2	0	75%	0611 – 40 HP	\$17,370	\$24,890	\$42,260	80
2	1	50%	0611 – 30 HP	\$23,490	\$28,320	\$51,810	90
3	0	33%	0308 – 20 HP	\$16,160	\$24,630	\$40,790	60
3	1	33%	0308 – 20 HP	\$21,560	\$32,840	\$54,400	80
4	0	25%	0306 – 15 HP	\$20,080	\$32,410	\$52,490	60

Perceived barriers to parallel pumping

“Installing more pumps in parallel will use up more space in my mechanical room”

Calculating Pump Footprint

Footprint is calculated by multiplying the largest length and width dimensions of the pump.

A spacing of 36" is assumed between pumps to allow access to integrated electronics

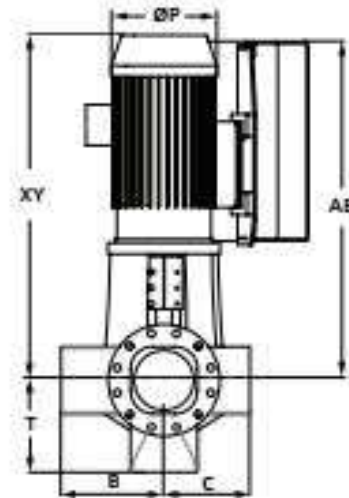
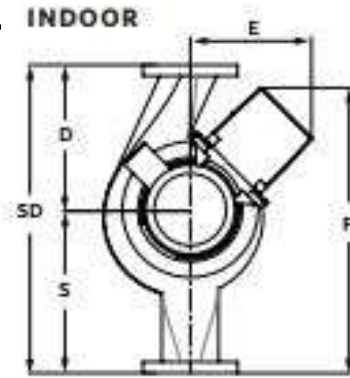

Reducing the Amount of Required Floor Space

"Standard" HSC
(66.0 ft²)

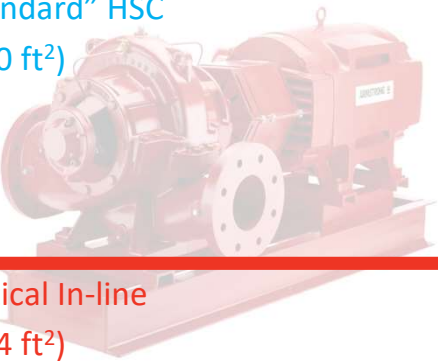

Vertical In-line
(14.4 ft²)

This image shows a large, red, horizontal end suction pump mounted on a base. The pump has a large circular suction port on the left side. A red box highlights the vertical in-line configuration, which is significantly smaller than the standard horizontal configuration.

Vertically Mounted HSC
(42.0 ft²)



Vertical In-line
(14.4 ft²)

This image shows a vertically mounted horizontal end suction pump. The pump is oriented vertically, with the suction port at the bottom. A red box highlights the vertical in-line configuration, which is the same size as the other vertical configurations.

"Rabbit Ear" HSC
(36.0 ft²)



Vertical In-line
(14.4 ft²)

This image shows a "Rabbit Ear" horizontal end suction pump, which has a distinctive shape with two large, curved suction ports. A red box highlights the vertical in-line configuration, which is the same size as the other vertical configurations.

Horizontal End Suction
(28.5 ft²)



Vertical In-line
(14.4 ft²)

This image shows a horizontal end suction pump with a more compact design than the standard version. A red box highlights the vertical in-line configuration, which is the same size as the other vertical configurations.

VIL Retrofit Replacing HSC Pumps



Footprint Comparison

Duty	SB	Flow Per Pump	Pump Selection	Total First Cost	Total HP	Footprint (sq. ft)
1	1	100%	0815 – 50 HP	\$58,050	100	33
2	0	50%	0611 – 30 HP	\$34,540	60	23
2	0	75%	0611 – 40 HP	\$42,260	80	32
2	1	50%	0611 – 30 HP	\$51,810	90	39
3	0	33%	0308 – 20 HP	\$40,790	60	22
3	1	33%	0308 – 20 HP	\$54,400	80	31
4	0	25%	0306 – 15 HP	\$52,490	60	24

Perceived barriers to parallel pumping

“I need a true standby pump because my client requires a certain amount of redundancy”

Behavior of parallel pumps during pump failure

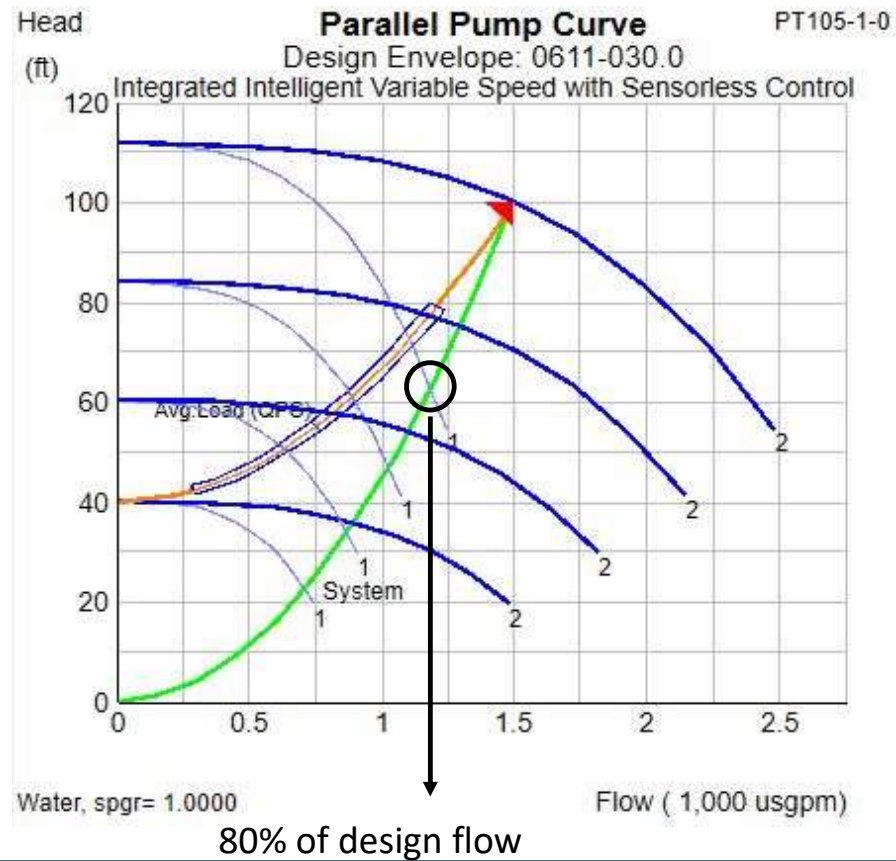

Impact of Reduced Flow on Heating or Cooling Output

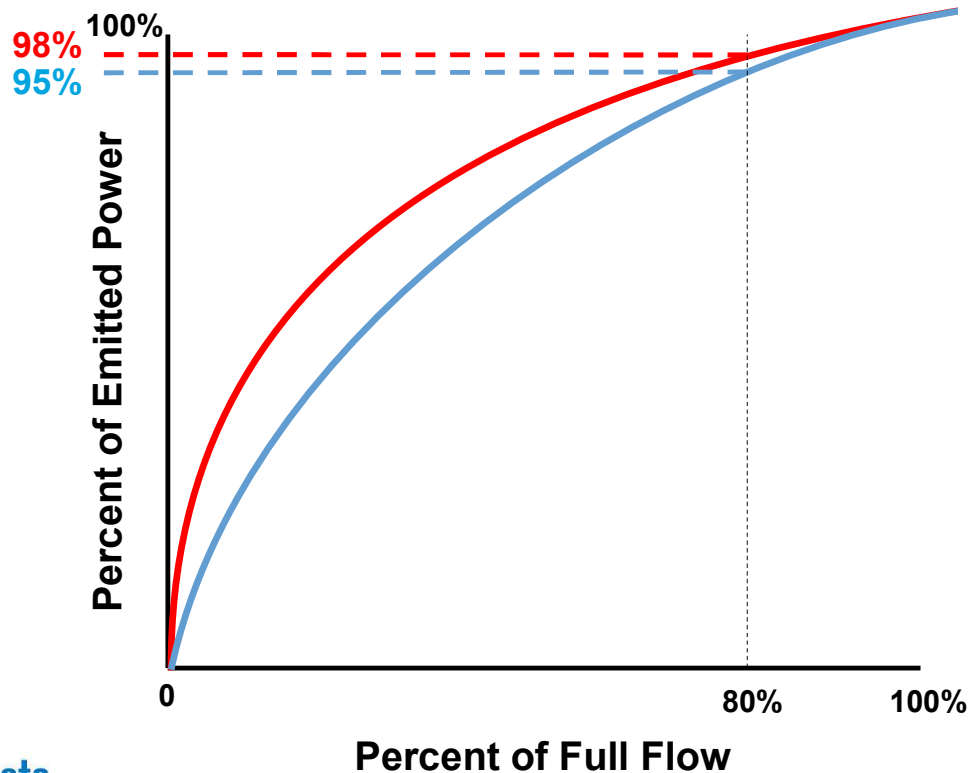

80% capacity under design conditions still results in approximately 95% or greater heating/cooling coil emission, resulting in minimal impact to occupant comfort

Redundancy in HVAC Pumping Systems

- How important is redundancy to an installation?
- Designs that maximize redundancy may be at odds with other criteria such as project budget or energy efficiency/sustainability
- Increased redundancy may have additional first costs, increased annual operating costs and may not be necessary



Redundancy Comparison

Duty	SB	Flow Per Pump	Pump Selection	Total First Cost	Total HP	Footprint (sq. ft.)	Flow Redundancy
1	1	100%	0815 – 50 HP	\$58,050	100	33	100%
2	0	50%	0611 – 30 HP	\$34,540	60	23	80%
2	0	75%	0611 – 40 HP	\$42,260	80	32	87%
2	1	50%	0611 – 30 HP	\$51,810	90	39	100%
3	0	33%	0308 – 20 HP	\$40,790	60	22	80%
3	1	33%	0308 – 20 HP	\$54,400	80	31	100%
4	0	25%	0306 – 15 HP	\$52,490	60	24	90%

Perceived barriers to parallel pumping

“Larger pumps are more efficient, so it’s going to be cheaper for me to operate one large pump instead of several smaller pumps”

Optimizing Pumping Systems

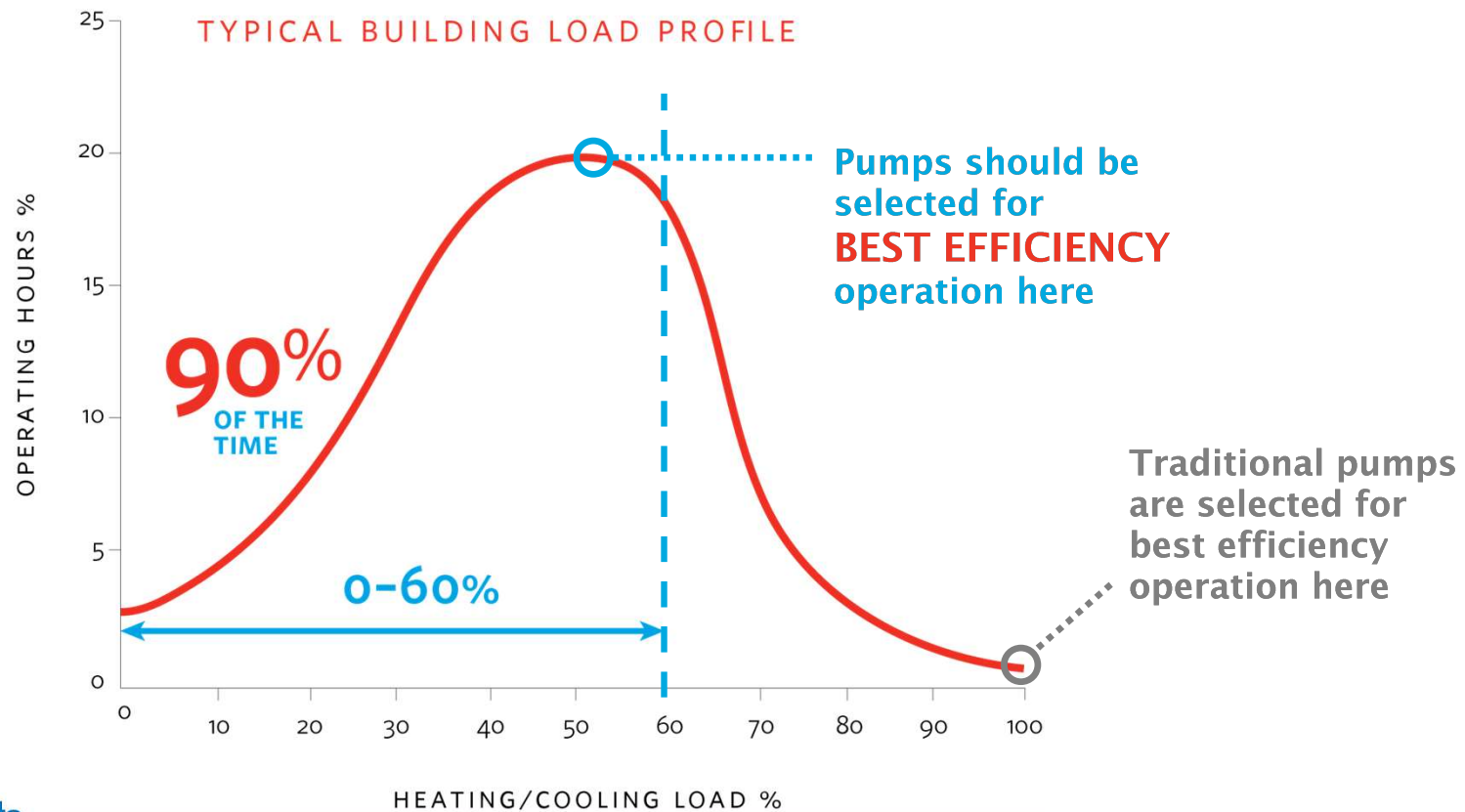

Pump Selection Strategies

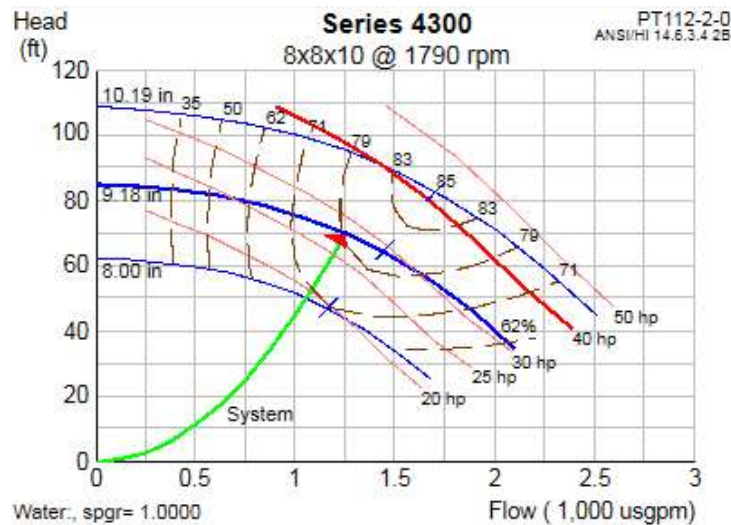

Efficiency @ Design: 79.1%
Brake HP @ Design: 27.9 HP

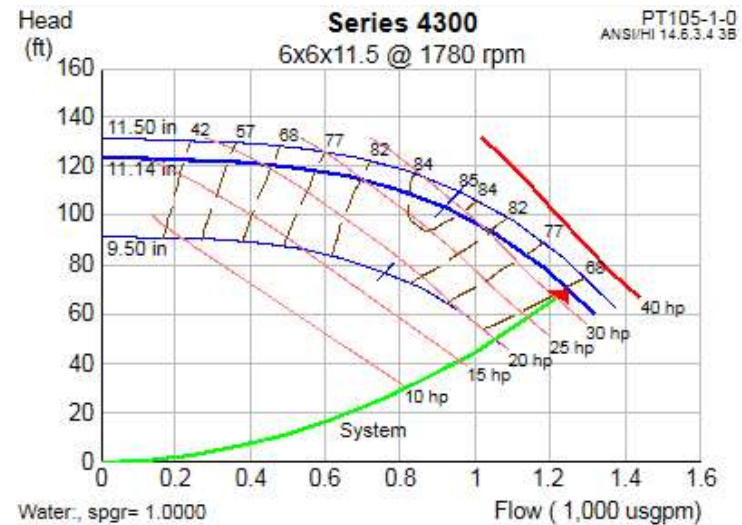

Efficiency @ Design: 68.1%
Brake HP @ Design: 32.5 HP

Design Conditions: 1,250 GPM @ 70 ft.
Variable Speed Application

Pumps selected to the left of best efficiency fail to meet ASHRAE 90.1 standards

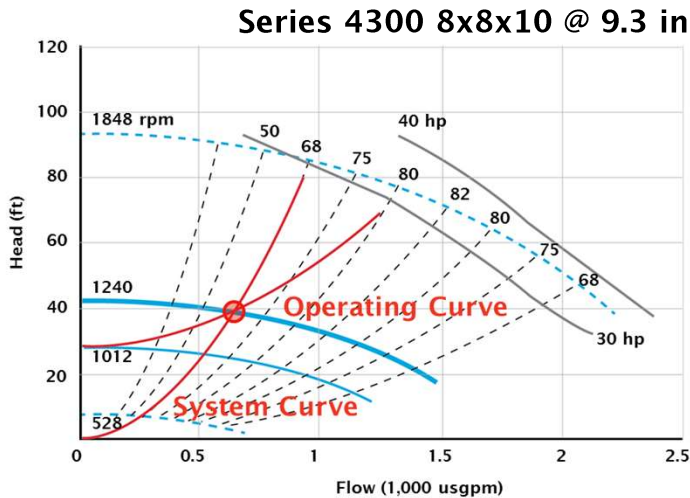
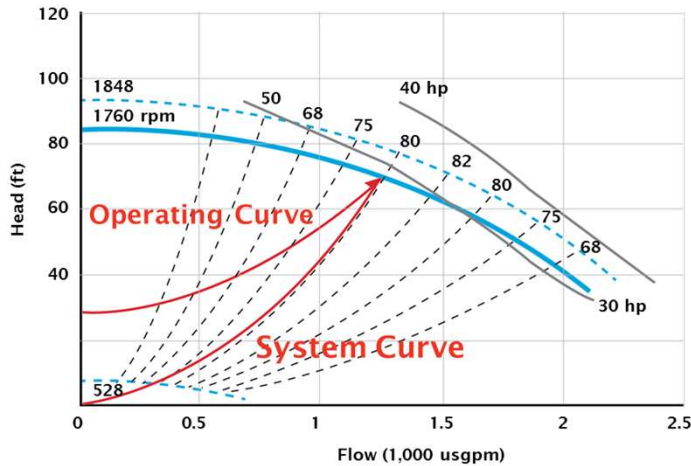

Design Condition
1250 gpm @ 70 ft.
79.1%
27.9 BHP

50% Design Flow
625 gpm @ 38.5 ft.
67.1%
9.06 BHP

Duty
Efficiency
Power

67.5% Energy Savings

Pumps selected to the right of best efficiency meet ASHRAE 90.1 standards

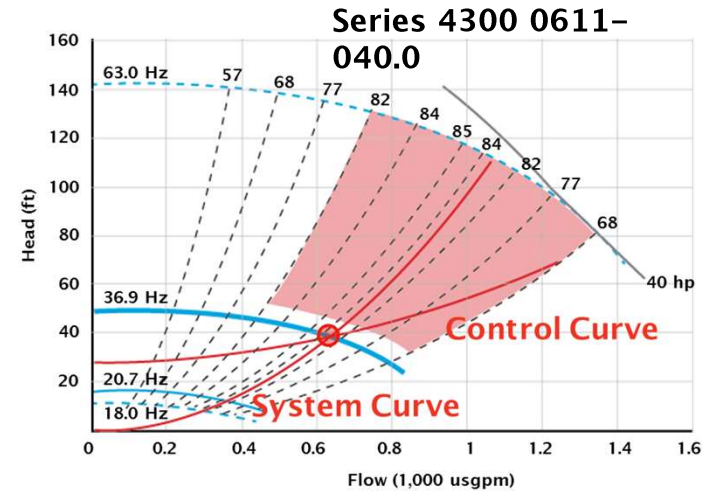
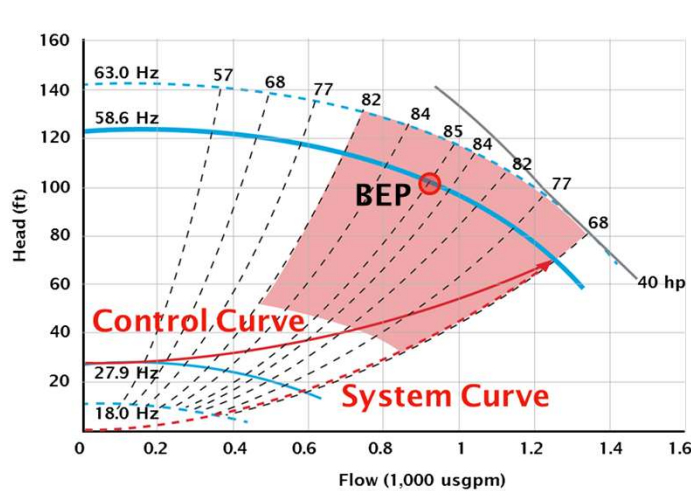

Design Condition	
Flow	1250 gpm @ 70 ft.
Efficiency	68.1%
Power	32.5 BHP

50% Design Flow	
Flow	625 gpm @ 38.5 ft.
Efficiency	83.2%
Power	7.31 BHP

Duty
Efficiency
Power

77.5% Energy Savings

Part-Load Efficiency Comparison

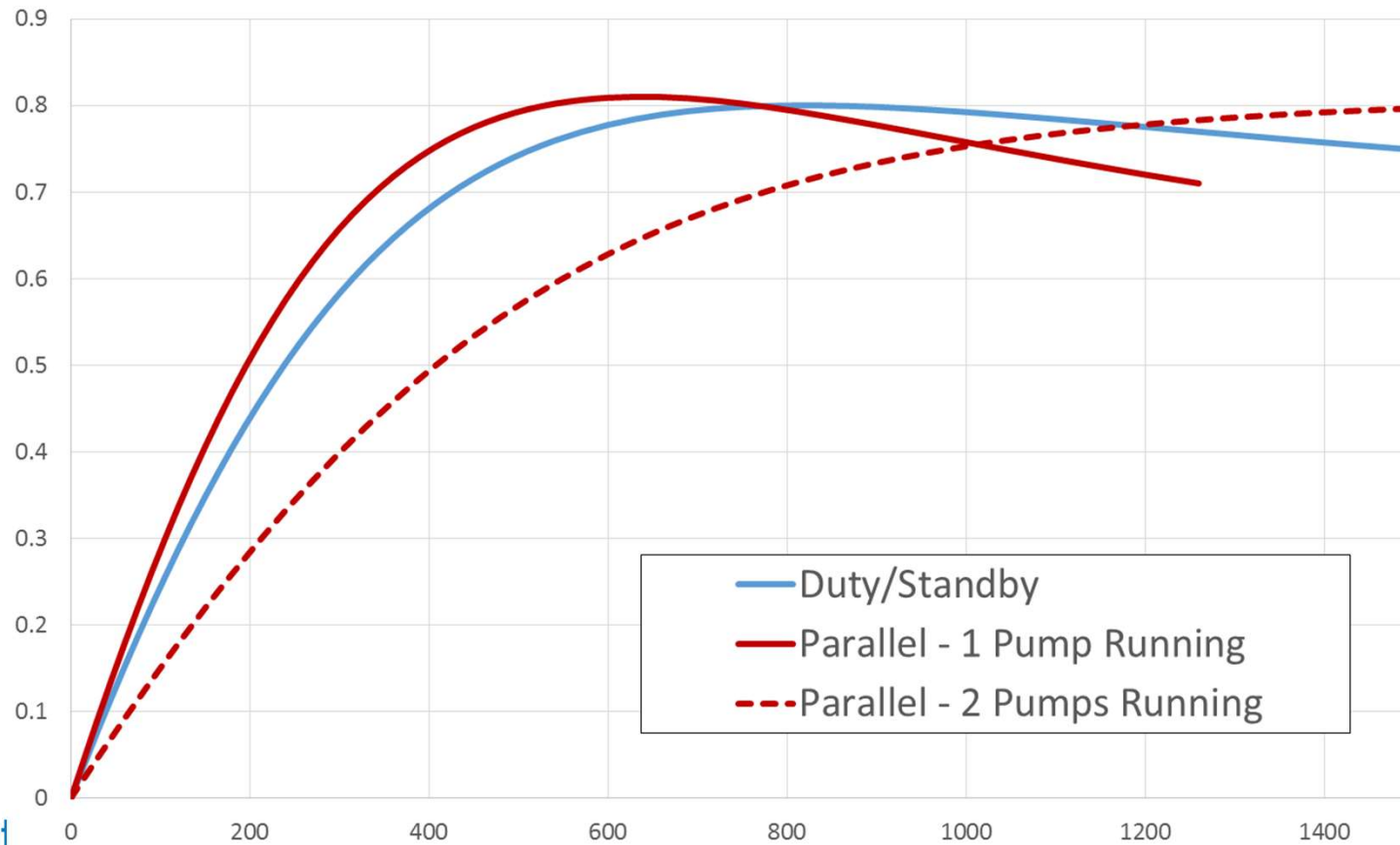

Operating Cost Comparison

Duty	SB	Flow Per Pump	Pump Selection	Total First Cost	Total HP	Sq. Ft.	Flow Red.	Operating Cost
1	1	100%	0815 – 50 HP	\$58,050	100	33	100%	\$9,110
2	0	50%	0611 – 30 HP	\$34,540	60	23	80%	\$8,380
2	0	75%	0611 – 40 HP	\$42,260	80	32	87%	\$9,080
2	1	50%	0611 – 30 HP	\$51,810	90	39	100%	\$8,380
3	0	33%	0308 – 20 HP	\$40,790	60	22	80%	\$9,140
3	1	33%	0308 – 20 HP	\$54,400	80	31	100%	\$9,140
4	0	25%	0306 – 15 HP	\$52,490	60	24	90%	\$8,880

Perceived barriers to parallel pumping

“Parallel pumping requires staging pumps on and off, which reduces the overall life expectancy of my pumps”

Startup torque is less of an issue now than it was in the past

VFDs allow for soft start, which reduces the impact that starting and stopping pumps has on overall equipment life



Parallel pumping improves time spent in the pump's Preferred Operating Range

The Hydraulic Institute recommends that pumps operate between 70% and 120% of flow at best efficiency point, known as the Preferred Operating Range

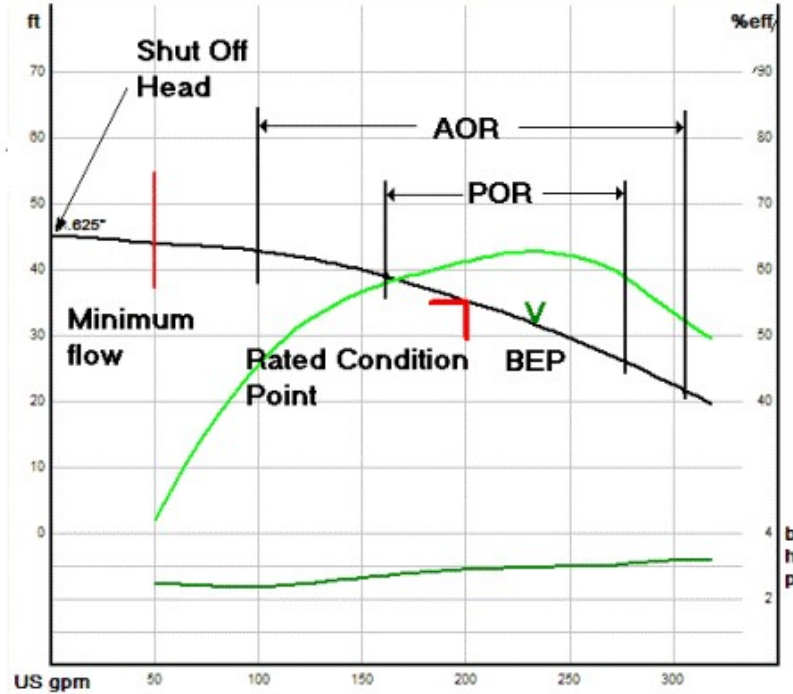

Impact of Operating Point on Component Life Expectancy

Pump Component	Flow Range Relative to BEP		
	-10% to +5%	-20% to +10%	-30% to +15%
Impeller	98%	88%	68%
Housing	86%	73%	70%
Bearings	98%	79%	65%
Seals	98%	88%	51%
Shafts	98%	79%	65%
Coupling	99%	92%	76%

Parallel Pumping Increases Time Spent in the Preferred Operating Range

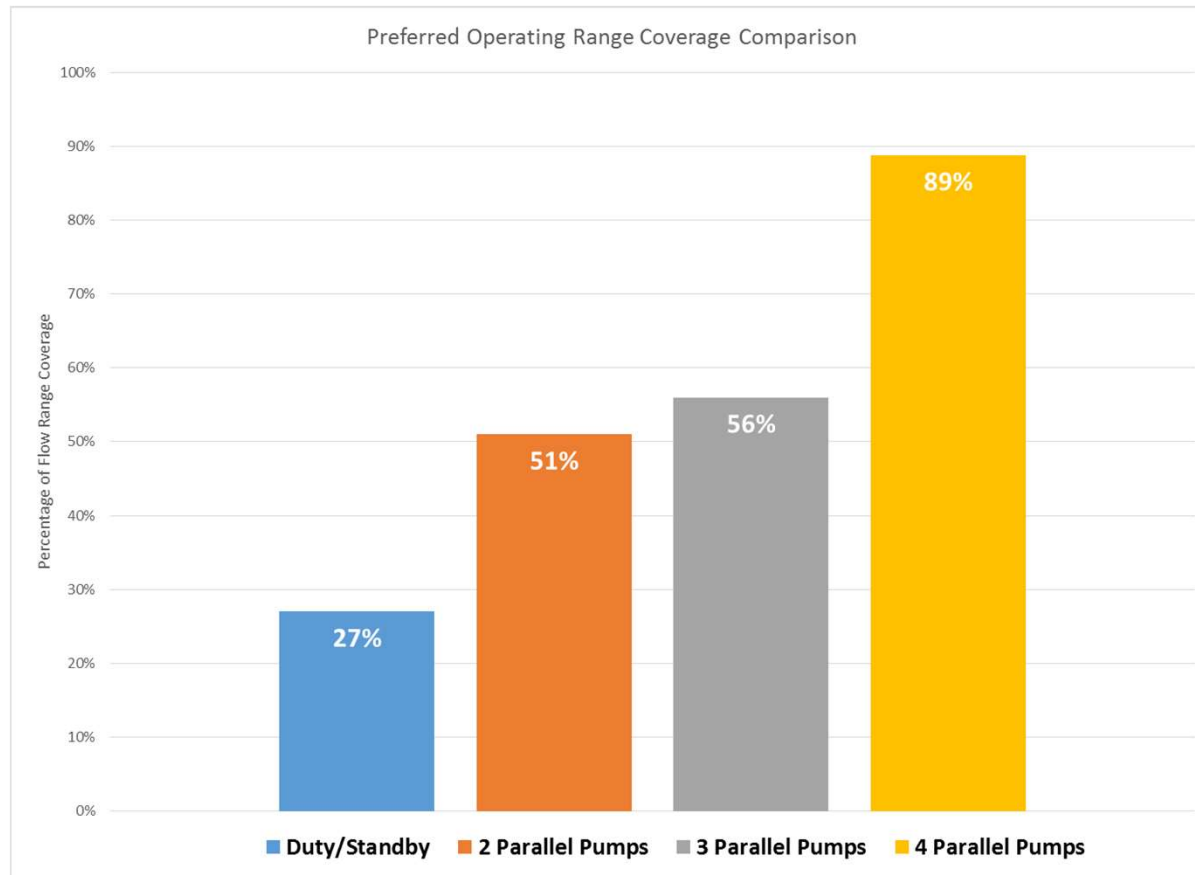

Perceived barriers to parallel pumping

“It’s more complex to control parallel pumps, so I’m going to end up spending all those savings on the control strategy”

Comparison of Pump staging strategies

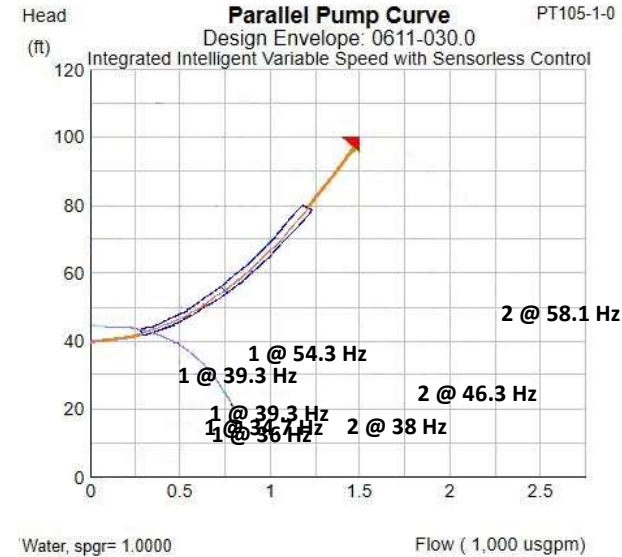
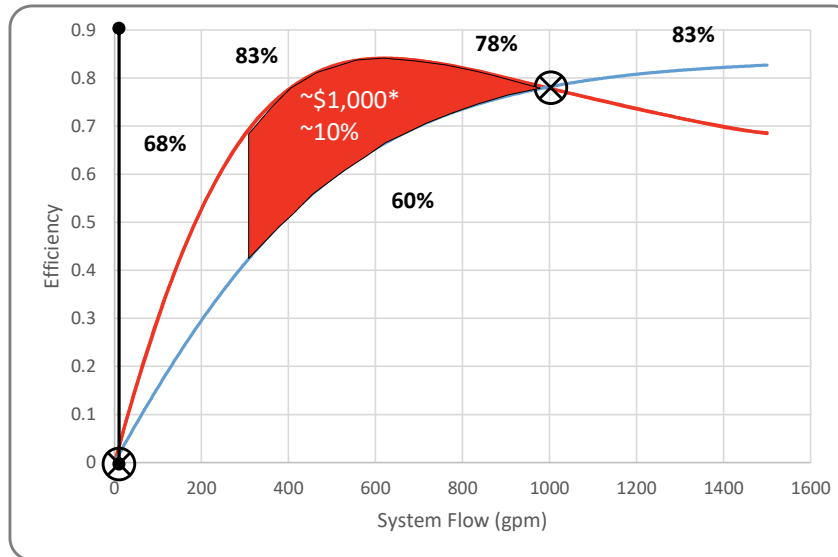

*at \$0.10/kW-hr for 8,760 operating hours

Efficiency Based Staging (BES)

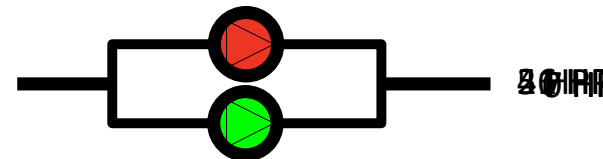

Speed Based Staging (SBS)

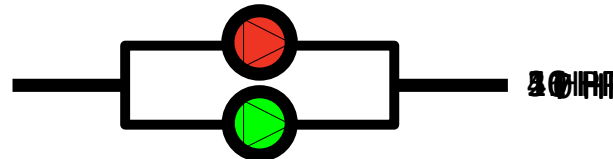

Efficiency Based Staging - Performance Benefits

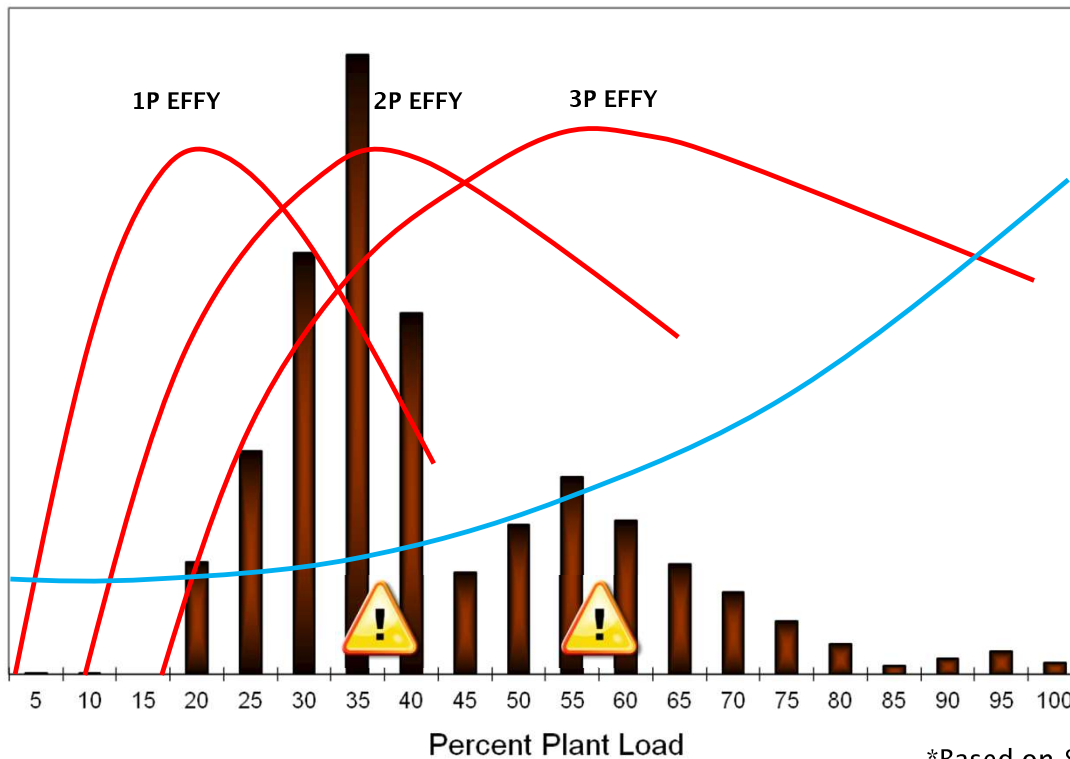

 = Areas of highest inefficiency

Energy Savings:
3 x 20 HP Pumps

Operating Cost* -
Speed Based Staging
~ \$9,530

Best Efficiency Staging
~ \$9,130

4% Additional Savings

*Based on \$0.10/kWh - 12 months operation - 40% design head min pressure

Summary of All Design Strategies

Duty	SB	Flow Per Pump	Pump Selection	Total HP	Sq Ft.	Flow Red.	Total First Cost	Op. Cost	10-Year Cost to Own
1	1	100%	0815 – 50 HP	100	33	100%	\$58,050	\$9,110	\$188,960
2	0	50%	0611 – 30 HP	60	23	80%	\$34,540	\$8,380	\$154,850
2	0	75%	0611 – 40 HP	80	32	87%	\$42,260	\$9,080	\$171,680
2	1	50%	0611 – 30 HP	90	39	100%	\$51,810	\$8,380	\$177,560
3	0	33%	0308 – 20 HP	60	22	80%	\$40,790	\$9,140	\$176,330
3	1	33%	0308 – 20 HP	80	31	100%	\$54,400	\$9,140	\$195,380
4	0	25%	0306 – 15 HP	60	24	90%	\$52,490	\$8,880	\$186,570

Options for Critical Facilities (100% Redundancy)



Hospitals



Data Centers



Mission Critical

Duty	SB	Flow Per Pump	Pump Selection	Total HP	Sq Ft.	Flow Red.	Total First Cost	Op. Cost	10-Year Cost to Own
1	1	100%	0815 – 50 HP	100	33	100%	\$58,050	\$9,110	\$188,960
2	1	50%	0611 – 30 HP	90	39	100%	\$51,810	\$8,380	\$177,560
3	1	33%	0308 – 20 HP	80	31	100%	\$54,400	\$9,140	\$195,380

Options for Non-Critical Facilities (<100% Redundancy)



Apartments/Condos

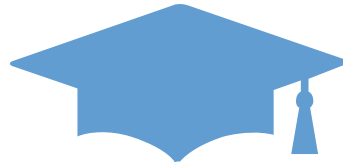

Schools



Commercial/Mixed-Use

Duty	SB	Flow Per Pump	Pump Selection	Total HP	Sq Ft.	Flow Red.	Total First Cost	Op. Cost	10-Year Cost to Own
2	0	50%	0611 – 30 HP	60	23	80%	\$34,540	\$8,380	\$154,850
2	0	75%	0611 – 40 HP	80	32	87%	\$42,260	\$9,080	\$171,680
3	0	33%	0308 – 20 HP	60	22	80%	\$40,790	\$9,140	\$176,330
4	0	25%	0306 – 15 HP	60	24	90%	\$52,490	\$8,880	\$186,570

In Conclusion...

- There is no silver bullet...pumping system design is dependent on many factors
- The compact footprint of vertical in-line integrated pumps makes them ideal for parallel pumping
- In almost all cases, parallel pumping will be less expensive, more efficient, and smaller than D/S
- Parallel pumping yields greater redundancy than expected
- Modern pump staging strategies can further increase operational savings associated with parallel pumping

For Further Information

Please contact me at:

Afurst@armstrongfluidtechnology.com

Or Go to:

WWW.Armstrongfluidtechnology.com